



POM series

378 - 930 kW

- three - pass design*
- high efficiency*
- cast iron sections*



Dimensions :

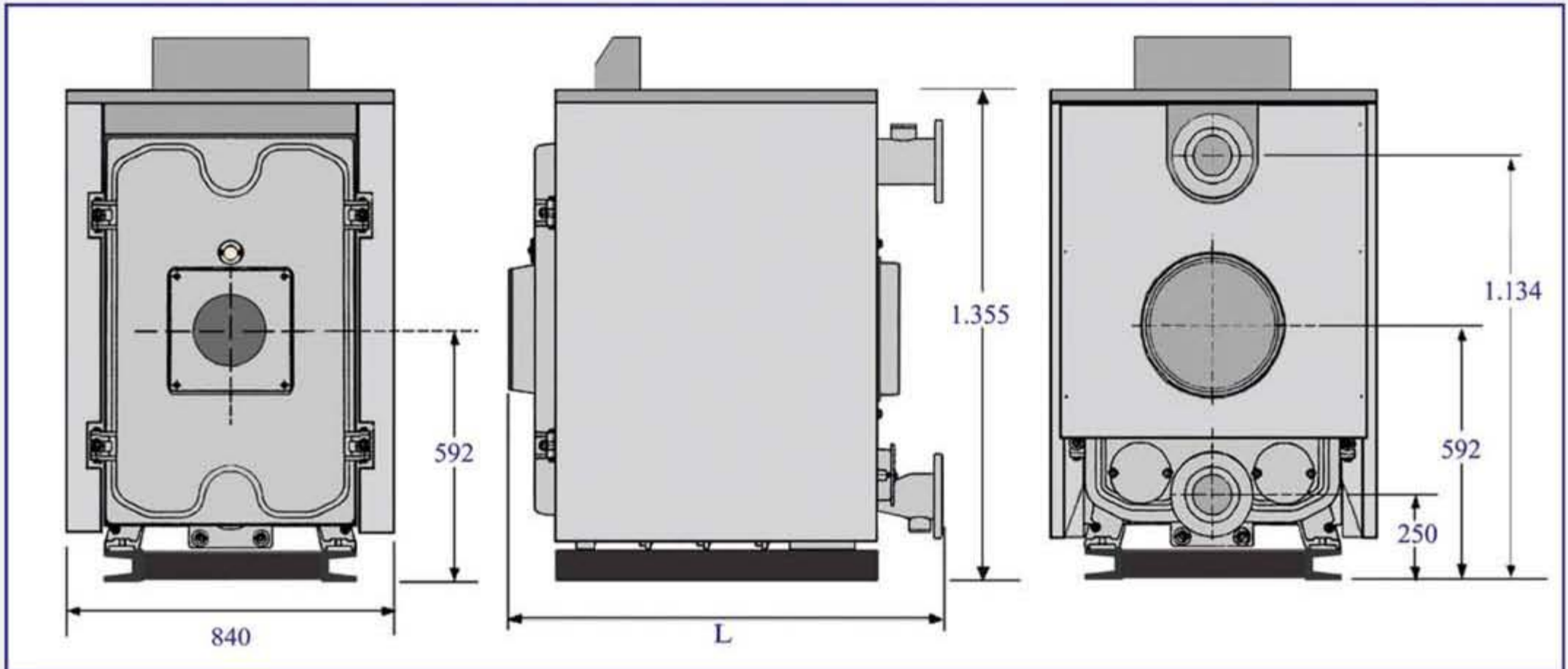

POM series cast iron boilers heat transfer surface area is enlarged with the special wings in chimney ways and combustion area . With special designed flame delay turbulators, maximum heat is transferred to the water in the sections for gaining high efficiency.

Sections are produced with flexible casting technique , EN GJL 200 special cast iron alloy , which gives high resistance against corrosion and thermal expansions.

POM series boilers produce more energy with less fuel by its high efficiency and perfect heat isolation.

Burning gases move three times in the boiler with the help of three pass cast iron sections and this minimizes the chimney gas output temperature.

Installation, operation and controls can easily be done with the help of both side opening burner door.

Boilers can easily be delivered and installed to the boiler room as it is delivered not assembled.



Thermix is a system designed by Pratikel . With tightening cross sectioned design and with turbulence wings , adaptor gives high speed to the return water of the boiler. Hot boiler water in the back sections of the boiler can be transferred to the front sections with the help of this turbulanced high speed water. With this way , hot water mixes with cold return water of boiler and temperature of return water increase .As temperature of the water which goes to back side of the boiler rises, condensing is prevented.



POM series automatic eco control panel

Technical Data :

Model		POM 06	POM 07	POM 08	POM 09	POM 10	POM 11	POM 12	POM 13	POM 14	POM 15	POM 16
Number Of Sections	Pcs.	6	7	8	9	10	11	12	13	14	15	16
Heat Output	kW	378	448	506	564	610	663	715	773	831	878	930
	kCal/h	325.000	385.000	435.000	485.000	525.000	570.000	615.000	665.000	715.000	755.000	800.000
Heat Input	kW	410	487	551	615	665	720	777	839	900	956	1.013
Operating Temperature	max °C	90										
Range Of Temperature Control	°C	30 - 90										
Gas Side Resistance	mbar	1,75 - 2,20	1,90 - 2,40	2,25- 2,75	2,55 - 3,10	2,80 - 3,35	3,15 - 3,70	3,45 - 4,05	3,80 - 4,35	4,10 - 4,75	4,45 - 4,95	4,85 - 5,50
Maximum Operating Pressure	Max. bar	6										
Boiler Water Content	Litres	149,5	174,0	198,5	223,0	247,5	272,0	296,5	321,0	345,5	370,0	394,5
	m ³	0,150	0,174	0,199	0,223	0,248	0,272	0,297	0,321	0,346	0,370	0,395
Exit Flue Connection Diameter	mm	350										
Combustion Chamber Dimensions	ø	501										
	L	mm	910	1.070	1.230	1.390	1.550	1.710	1.870	2.030	2.190	2.350
Water Input - Output Connection	DN (")	DN 100 (4")										
Gas Volume Of the Boiler	dm ³ (lt.)	341,74	400,71	459,68	518,65	577,62	636,59	695,56	754,53	813,50	872,47	931,44
	m ³	0,342	0,401	0,460	0,519	0,578	0,637	0,696	0,755	0,814	0,874	0,931
Gas Volume Of the Combustion Chamber	dm ³ (lt.)	179,39	210,93	242,48	274,02	305,56	337,10	368,64	400,18	431,73	463,27	494,81
	m ³	0,179	0,211	0,242	0,274	0,306	0,337	0,369	0,400	0,432	0,463	0,495
Safety Temperature Limiter	°C	100										
Boiler Type		ON / OFF										
Fuel Type	Gas	Natural Gas (I2H)										
	Liquid F.	Liquid Fuel (Extra Light Heat Oil)										
Exit Flue Gas Temperature	Full Load °C	182 - 187	178 - 185	175 - 180	173 - 178	173 - 176	170 - 175	170 - 174	168 - 172	165 - 168	162 - 165	160 - 163
	Part Load °C	165 - 172	164 - 170	162 - 168	161 - 165	160 - 165	158 - 163	156 - 161	155 - 160	155 - 160	153 - 150	150 - 148
Exit Flue Gas Mass Flow (%13 CO ₂) % 60	Full Load kg / h	633	750	848	945	1.023	1.110	1.198	1.295	1.393	1.470	1.588
	Part Load kg / h	380	450	508	567	614	666	719	777	836	882	935
Chimney Effect	Pa	0										
Burner Type		Short Barrel										
Burner Flange Connection Dimension	mm	225										
Standby Loss	%	0.33	0.31	0.28	0.27	0.24	0.22	0.20	0.18	0.17	0.16	0.14
	kCal/h	11.583	12.890	13.154	14.143	13.608	13.543	13.284	12.928	13.127	13.046	12.096
Boiler Length (L)	mm	1.300	1.460	1.620	1.780	1.940	2.100	2.260	2.420	2.580	2.740	2.900
Dry Weight	Kg.	1.090	1.230	1.370	1.510	1.650	1.790	1.940	2.080	2.220	2.360	2.500
CE - Registration Number		CE-1015BR0262										

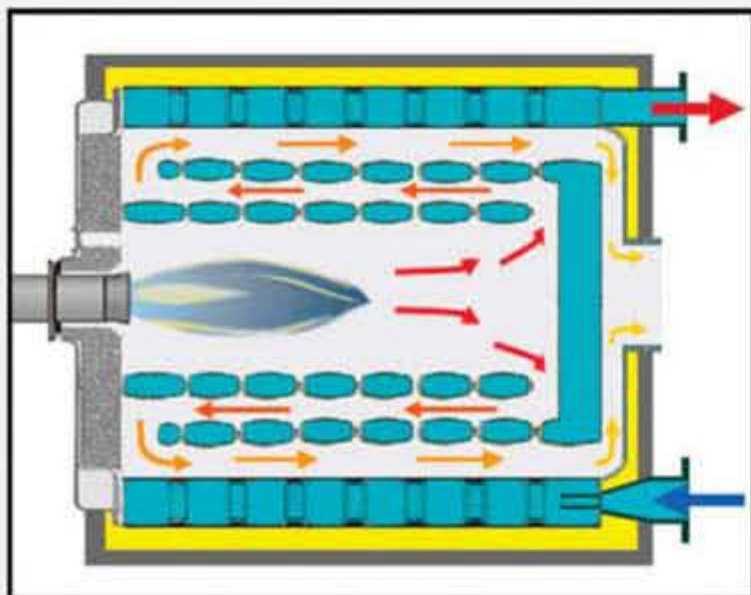

Three draught design forces the flue gas to circulate inside the body of the boiler three times before the chimney exit, transferring all usefull energy to the water inside the sections . The optimized combustion chamber combined with perfect heat insulation provides maximum fuel efficiency.